



Precise, reliable, safe tank measurement: the benefits of experience.

The SmartRadar FlexLine automatic tank gauge (ATG) combines innovative software algorithms with our proven planar antenna technology for the precision you need in custody transfer and inventory applications. It provides consistent accuracy even under the toughest operating conditions, whether on domed roofs, bad stilling wells or when installed close to the tank shell. With the wireless option you can use it in the ISA100 wireless (IEC 62734) universal mesh network, seamlessly integrate it into any supervisory system, for better productivity, reliability, safety, security, and regulatory compliance. SmartRadar FlexLine is TÜV certified for use in safety rated loops up to SIL 3 as per IEC 61508, meets major recommendations such as API 2350 and is widely used in overfill protection loops to prevent overfill accidents.

Global Experience. Locally Applied.



With a modular build, SmartRadar FlexLine, provides flexibility, letting you add options easily. Supporting multiple functions, it covers all tank gauging needs. The base Radar module measures the product level by the microwave unit and antenna. In addition six optional modules can be housed in the FlexLine SmartRadar, to meet various I/O requirements of tank gauging.

FlexLine offers best in class accuracies with no drift from ambient temperature effects. Xtreme Performance and High Performance models are certified as per OIML R85:2008 recommendations and can be used for country specific legal metrology approvals within all OIML member states. The Advanced Performance SmartRadar FlexLine is for use in inventory control measurement requirements as per API MPMS Ch. 3.1B recommendations.

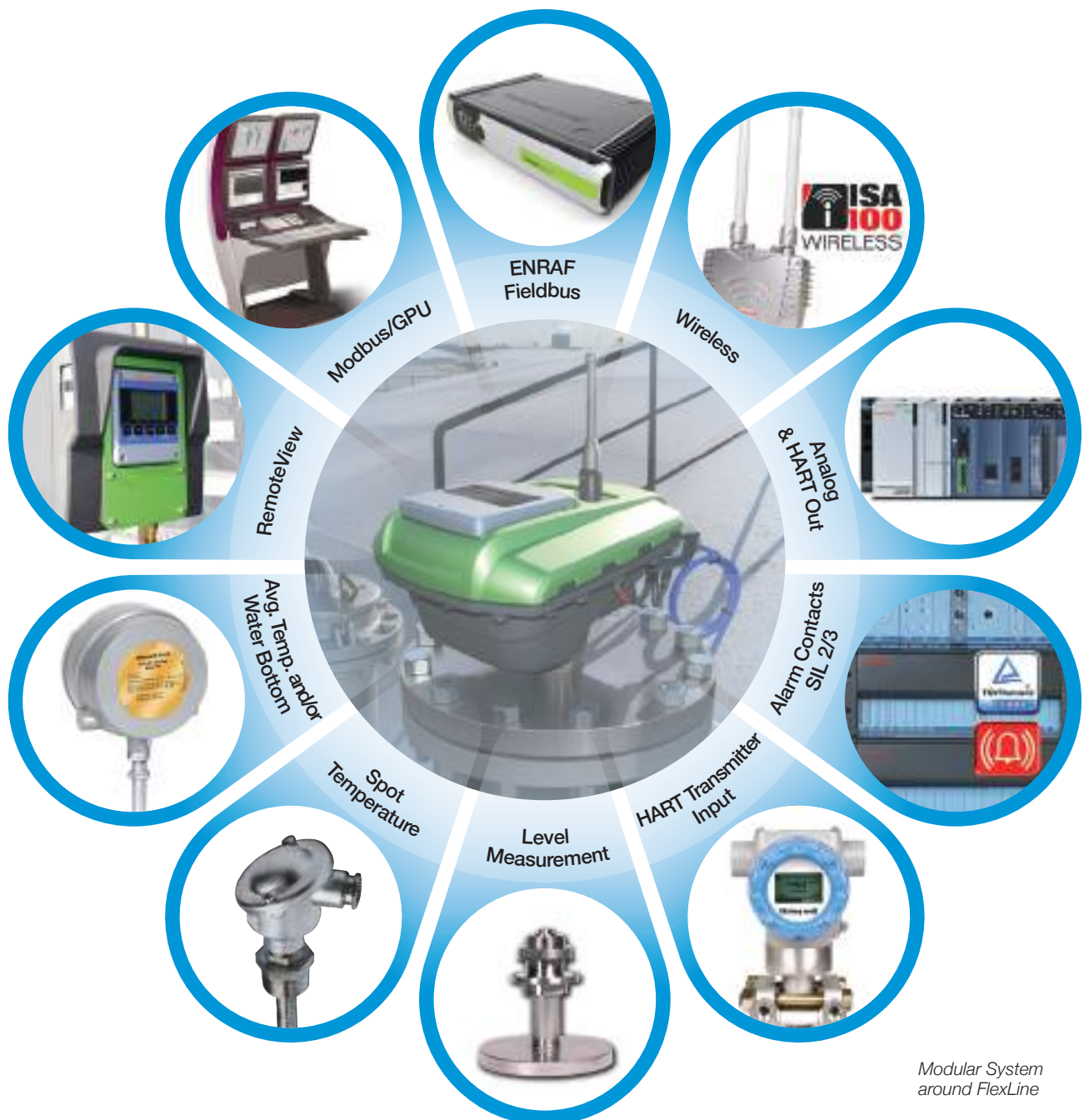

Modular System around FlexLine

Modular System

Enraf Field Bus–Interfacing Host

Robust and proven communications that go the distance

With hardly any special requirements on cable quality, the Bi-Phase Mark (BPM) is the current industry standard in tank gauging systems. The 2-wire BPM allows for cable lengths of at least 10 km (6 miles) and can be run over almost any existing cabling. It is suitable for communication between various models of tank gauges and Honeywell Enraf's Tank Inventory Management system and other supervisory systems through Communication Interface Units (CIUs). A high level of isolation is offered through a specially developed isolation transformer employed on both ends of the communication line.

Features

- Uses existing infrastructure
- Robust (unique lightning protection)
- The de facto standard in tank farm automation
- Covers long distances (more than 10 km/6 miles)

HART® and Analog Input Connectivity Master

Seamless integration of HART® devices

SmartRadar FlexLine supports all I.S. HART® compliant devices with a maximum of five connected devices per interface. When used in analogue mode, one process value (PV) can be measured. In combination with a capable HART® pressure transmitter, it can be used for HART® hybrid inventory measuring systems (HIMS). The HART® connectivity can also be used for other tank application such as water bottom detection, temperature measurement and density. The module also supports roof immersion compensation with connected HART® sensors.

Features

- Optimize your inventory by integrating temperature and pressure measurements
- Install multiple HART® modules in one FlexLine gauge
- Up to 5 connected HART® devices per interface
- If used in combination with the VITO interface, three additional HART® devices can be connected
- FlexLine can be used as a data-concentrator for other functions such as ambient temperature measurements, Floating roof monitoring (FRM), fire detection and roof immersion compensation.

Wireless Connectivity

A new level in flexibility

With the integrated OneWireless solution, Honeywell Enraf gauges use the ISA100 wireless (IEC 62734) OneWireless universal mesh network to seamlessly integrate with any supervisory system, such as Entis, Experion PKS or other DCS. OneWireless helps optimize plant productivity and reliability, improve safety and security, and ensure regulatory compliance. The OneWireless option integrated in the FlexLine is simple to manage and efficient to operate, while the ISA100 wireless infrastructure allows for remote monitoring of installed equipment and supports full diagnostics.

Features

- FlexLine can function as a “data concentrator” to transfer all tank information, including connected HART® devices, over wireless to the supervisory systems
- Over-the-air key provisioning removing the need to climb on tank tops
- The signal hopping feature within the FlexLine ensures continuous availability and reliability of communication.

Benefits

- Reduce installation cost by 50% or more through wireless connectivity
- Improve inventory accuracy by migrating to high-precision ATG without the need to run new cabling
- Reduce operational costs by integrating wired and wireless devices in the same tank management software.

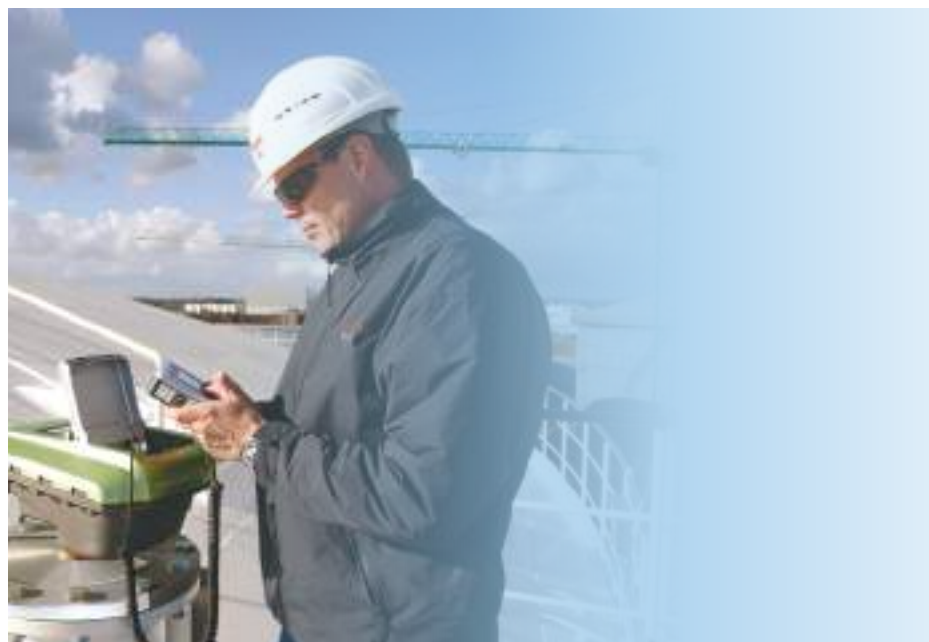



Safety Functions

SIL certified protection for safe operation

Certified by the TÜV for use in Safety Integrity Level (SIL) rated loops, FlexLine is a solution to prevent overflow and/or dry run. With a Safe Failure Fraction of 97% it is suitable for use in SIL 2 safety loops and SIL 3 loops when used in redundant configuration. High diagnostic coverage allows the safety proof-test interval to be extended, bringing down operational costs. Dual redundancy with 2oo4D voting of the safety function automatically detects and reports failures in the safety circuitry, while allowing the gauge to continue to function as a safety device without interrupting the process. Higher availability means better efficiency. It's industry best internal diagnostic cycle time of <1 second, allows higher threshold settings, accommodating more storage space with bulk petroleum storage tanks.

Features

- Certified by TÜV for SIL 2/SIL 3 rated loops as per IEC 61508:2010 and IEC 61511:2004
- Proof test interval of >10 years to reduce operational costs
- 2oo4D configuration increases safety as well as availability
- Internal diagnostic cycle time of < 1sec
- Independent twin safety functions, for example overflow and under-fill (dry-run) prevention, possible.
- Fully compliant with API 2350 standard
- Meets critical safety recommendations of having a high integrity, automatic operating overflow prevention system (or a number of such systems, as appropriate) that is physically and electrically separate and independent from the tank gauging system.

Alarm Contacts (Digital Outputs)

Digital outputs for alarm signaling or control functions

Multiple relay contacts are offered for digital outputs associated with a wide range of common devices, such as relays, contactors, starters and two-position actuators. Contacts can be controlled remotely or switched automatically and linked to measured parameters, such as level, temperature, or pressure. The module provides four relay contacts that can be manually set to be normally open or normally closed and configured to be normally energized or normally de-energized for failsafe behavior.

Features

- Two different contact ratings
- Two or four relays wired to connecting terminals
- Ultimate flexibility in alarm signaling

Planar Antenna Technology (PAT) - Free Space and Stilling Wells

Easy to fit on roof nozzles and for all sizes of stilling wells

While the free space planar antenna is ideal in roof nozzles on cone roof tanks or dome roof tanks, Stilling well version of planar antenna are used for stilling well applications.

Together with 6" and 8" free space antennas and different stem lengths, SmartRadar FlexLine provides easy answers for a range of different roof nozzles on cone roof and dome roof tanks. For tanks with stilling wells, the SmartRadar planar antenna comes in different sizes and covers 6", 8", 10", 12", 16", 20" and 24" stilling well sizes.

Planar antennas are suitable for use in process pressure conditions up to 6 bar (87 psi) and can be used in extreme temperature conditions of as low as -200 °C (-328 °F) and up to +250 °C (+482 °F).

High Pressure 4" Horn Antenna

Antenna for pressurized liquids up to 40 bar (580 psi)

This horn antenna is developed for high pressure applications, such as LPG and chemical gasses. It is designed for spheres and bullets equipped with a 4" Sch 10/40 stilling well or a 4" Sch10 insert pipe. Easy verification of radar level measurement is possible using verification pins. The high pressure tank separator provides both an approved and safe process seal. The Horn antenna is offered with an optional 1" ball valve or can also be installed on top of a 4" ball valve.

Technical Specification

Measuring Principle	
Measuring principle	FMCW/Synthesized Reflectometer
Signal processing	Fully digital using Enhanced Performance Signal Processing (EPSP)
Operating frequency	Xband (9.538 GHz to 10.561 GHz) R&TTE, FCC compliant
Measuring Specifications	
Measuring range	Up to 75 m (246 ft)
Instrument accuracy level	<ul style="list-style-type: none"> – Xtreme performance SmartRadar ± 0.4 mm (± 0.016"^{*1 *2 *3 *4}) – High performance SmartRadar ± 1 mm (± 0.04"^{*1 *2 *3}) – Advanced performance SmartRadar ± 3 mm (± 0.12"^{*1})
Measuring resolution	0.1 mm (0.001")
Update time	0.1 sec
Mechanical	
Dimensions	217 x 319 x 379 mm (8.55" x 12.55" x 14.9") (H x W x L) ^{*5}
Weight	≈16 kg (35 lb), depending on installed options and excluding antenna and tank separator
Cable entries	3 x ¾" NPT ^{*6} or 6 x M20 ^{*7}
Process	
Max. process pressure	<ul style="list-style-type: none"> – Planar (PAT) Antennas: up to 6 bar / 0.6 MPa (87 psi) – Horn Antennas: up to 40 bar / 4 MPa (580 psi)
Process temperature range	-200 °C to +250 °C (-328 °F to +482 °F) ^{*8, *9}
Process Wetted Materials	
Tank separator	Stainless steel AISI 316 (material no.: 1.4401) ^{*10}
Antenna materials	<ul style="list-style-type: none"> – Planar (PAT) antennas: SS AISI 316 (mat. no.: 1.4401) and FEP – High pressure horn antennas: SS AISI 316 (mat. no.:1.4401) and PTFE (in high pressure tank separator) – Ball valve (optional with horn antenna) stainless steel CF8M (mat no.: 1.4408)
O-rings	FPM (in tank separator) ^{*11}
Enclosure Materials	
Instrument housing	Cast aluminum alloy according to EN1706; AA A356 EN1706; AC-AISi7Mg0.3
Finish aluminum parts	Hard anodized according to MIL A8625-E Type III
Cover	Aluminum; coating: Polyurethane
O-rings	NBR 70
Environmental	
Ambient temperature	-40 °C to +65 °C (-40 °F to +149 °F)
Storage temperature	-50 °C to +75 °C (-58 °F to +167 °F)
Legal Metrology	
Weights & Measures	NMI, PTB, BRML, UMI, LNE, DZM, ONML, W&M India, PAC, MIGAS, OIML, and several others. Contact Honeywell representative for other legal metrology approvals.

Notes:

^{*1} Under reference conditions

^{*2} Certified as per OIML R85:2008

^{*3} Legal Metrology (W&M) and Custody Transfer Applications

^{*4} Selection "X" is additionally certified as per legal metrology requirements of Netherlands, France, Germany, Croatia, Bulgaria, Belgium, and for witness verification specify the authority (selection "X" in identification code)

^{*5} Refer to the dimensional drawing shown in this document.

Technical Specification

Functional Safety and Overfill Prevention

SIL certification	TÜV certified for SIL 2 (single configuration, HFT= 0) and SIL 3 (redundant configuration, HFT=1), according to IEC 61508 & IEC 61511
Overfill protection	DIBt WHG, Corcon BVBA

Explosion Safety Approvals

Explosion safety approvals/certificates	<ul style="list-style-type: none"> – II 1/2 G Ex d [ia Ga] IIB T6 Ga/Gb; acc. to ATEX KEMA – Ex d [ia Ga] IIB T6 Ga/Gb; acc. to IECEx KEMA – Ex d ia IIB T6; acc. to Kosha certificate – Class I, Division 1, Groups C & D; acc. to FM – Class I, Division 1, Groups C & D; acc. to CSA – Ex d [ia Ga] IIB T6 Ga/Gb; acc. to INMETRO TÜV
Other approvals/certificates	Explosion proof: NEPSI, PESO (India), GOST-R
Ingress protection	IP66/IP67 (NEMA 4X)

For Other explosion safety approvals/certificates and updates, please contact Honeywell representative.

Electrical

Power supply	Autoselect 65 Vac to 240 Vac (+10% to -15%) 50/60 Hz and/or 24 Vdc to 65 Vdc (+10% to -15%)
Power rating	Typical 15 W; max. 23 W with all options
Maximum current (start-up)	I _{max} = 1.2 A

Data Communication

Enraf Field Bus (BPM)

Baud rate	1200 / 2400 bps
Cable characteristics	2 wires, twisted pair, R _{max} = 200 Ω / line, C _{max} = 1 μF; cable length: 10 km (6 miles) or more ¹²
Isolation voltage	> 1500 V
Lightning protection	Full galvanic separation using isolation transformers
Common mode rejection	> 150 dB
Protocol	Standard Enraf Fieldbus (serial, ASCII GPU protocol)

Wireless Communications

Wireless communication	2400 to 2483.5 MHz (2.4 GHz) Industrial, Scientific and Medical (ISM) band, Modulation: DSSS – Discrete Sequential Spread Spectrum per FCC 15.247 / IEEE 802.15.4-2006
DSSS RF Transmitter power ¹³	<ul style="list-style-type: none"> – NA Selection (per FCC/IC): 125 mW (20.9 dBm) maximum transmit power not including antenna, or 400 mW (26.0 dBm) maximum EIRP including antenna, for USA and Canada locations – EU Selection (per RTTE/ETSI): 10 mW (10.0 dBm) maximum EIRP including antenna, for EU locations
Signal range (nominal) ¹⁴	<ul style="list-style-type: none"> – NA Selection (per FCC/IC): <ul style="list-style-type: none"> • ≈1800 m (5900 ft) with +4 dBi integral antenna • ≈1800 m (5900 ft) with +4 dBi integral antenna – EU Selection (per RTTE/ETSI): <ul style="list-style-type: none"> • ≈600 m (1970 ft) with +4 dBi integral antenna • ≈900 m (3000 ft) with +8 dBi integral antenna
Connectivity	<ul style="list-style-type: none"> – Published data: All process values available in the FlexLine – Publish Cycle Time: Configurable as 1, 5, 10 or 30 seconds – Protocol Tunnels: GPU and FlexConn
Wireless antennas	Integral: +4 dBi or +8 dBi omni directional monopole, with or without lightning surge arrestor ¹⁵
Wireless compliance	IEC62734 (ISA100 Wireless)

Technical Specification

Data Communication (continued)	
RS-232 GPU Protocol / Standard Modbus Protocol	
Baud rate	1200 / 2400 / 4800 / 9600 / 19200 bps (configurable)
Isolation voltage	> 600 V
Lightning protection	Opto-isolators
Protocol	Serial ASCII GPU protocol / Standard Modbus protocol (software switchable)
Max. instruments per line	1 ; point to point
Cable characteristics	3 wires, shielded and twisted, max. cable length: 15 m (50 ft)
RS-485 GPU Protocol / Standard Modbus Protocol	
Baud rate	1200 / 2400 / 4800 / 9600 / 19200 bps (configurable)
Isolation voltage	> 600 V
Lightning protection	Opto-isolators
Protocol	Serial ASCII GPU protocol / Standard Modbus protocol (software switchable)
Max. instruments per line	32, multi point
Cabling	3 wires, shielded, twisted pair, signal ground, R _{max} = 0.12 Ω / m, C _{max} = 119 pF/m, L _{max} = 1.45 mH, max. cable length: 1200 m (3900 ft)
HART® Slave – Multidrop and/or 4-20 mA	
Protocol	Communications: HART® 6.2
Analog output loop (non-I.S.)	Active or Passive; selectable by jumper – Active: output voltage: 20V ±5% – Passive: minimum external supply voltage: 11.5 V maximum external supply voltage: 30 V (55 V with serial resistor)
Accuracy	±0.1 % of actual measurement
Burnout value	Low: 0 - 3.6 mA or High: 21 - 25 mA (configurable)
Cable characteristics	2 wires, shielded, twisted pair
SmartView Display – Integrated and/or Remote	
SmartView display	Refer to identification code for display options
Conn. with SmartView	Ex ia IIB ≈12 V
Cable characteristics for remote SmartView	4 wires, shielded, C _{max} = 3 μF, L _{max} = 0.48 mH, R _{max} = 8.5 Ω (one SmartView connected) or R _{max} = 4.7 Ω (two SmartViews connected)

Notes:

⁶ Exd only

⁷ Exe only

⁸ The temperature measured at process connection (Flange).

⁹ For cryogenic applications, the antenna is installed in the stilling well, above the tank roof, in an area with ambient temperature conditions. For cone roof / dome roof free space applications with a vapor temperature above +100 °C (+212 °F), the planar antenna shall be installed inside the roof nozzle above the tank roof.

¹⁰ Tank separators are available in free space (low pressure) and high pressure versions.

¹¹ Special O-rings (Perlast®) available for demanding chemical applications, part no.: U0990005.

¹² Distances of more than 10 km possible depending on amount of field instruments and cabling topology.

¹³ For other countries and/or geographical area's refer to local and national radio legislations.

¹⁴ Specified distance are between field transmitter and infrastructure unit (Repeaters or Gateways), with clear line of sight. Actual radio distances may be affected by local building and obstruction density closeness.

¹⁵ Lightning surge arrestors are recommended for lightening prone regions.

Technical Specification

Options	
Alarm Contact Options	
2 x SPDT contact	0.5 A at 125 Vac or 0.3 A at 110 Vdc, Pmax = 30 W
2 x SPDT contact	3 A at 250 Vac or 3 A at 40 Vdc, Pmax = 750 W
4 x SPDT contact	2 x SPDT contact, 0.5 A at 125 Vac or 0.3 A at 110 Vdc, Pmax = 30 W and 2 x SPDT contact, 3 A at 250 Vac or 3 A at 40 Vdc, Pmax = 750 W
Relay operation	<ul style="list-style-type: none"> – Normally Open/Normally Closed contact: selectable by jumper – Normally Energized / Normally De-energized: configurable by software setting – PV Monitor (any of the measured parameters, configurable by software setting) – Remote control (configurable by software setting)
SIL 2/3 Safety Functions Alarm Contacts	
Relay contact	1 x SPDT contact, 3 A at 250 Vac or 3 A at 40 Vdc, Pmax = 750 W ^{*16}
VITO Input for Temperature and Water Probe	
Communications	Proprietary HART® (Ex-i)
Cable characteristics	2 wires, shielded, twisted pair, Cmax = 1 µF, Lmax = 9 mH, Rmax = 25 Ω / line
Accuracy	<ul style="list-style-type: none"> – Temperature measurement: ±0.1 °C (±0.18 °F) ^{*17, *18} – Water level measurement: ±2 mm (0.078") ^{*17}
Resolution	<ul style="list-style-type: none"> – Temperature measurement: 0.01 °C (0.01 °F) – Water level measurement: 0.1 mm (0.01")
Spot RTD Input	
Configurations	<ul style="list-style-type: none"> – 3 wire or 4 wire RTD, one element or two elements ^{*19} – MPT or MRT up to 6 elements with 2 common ground wires ^{*19}
Cable characteristics	Shielded, Rmax = 100 Ω / line, Cmax = 1 µF, Lmax = 10.5 mH
Accuracy	±0.1 °C (±0.18 °F)
Resolution	0.01 °C (0.01 °F)
HART® Input	
Configurations	Options <ul style="list-style-type: none"> – 5 HART® inputs and / or HIMS density calculation – VITO sensors and / or 3 HART® inputs – 3 HART® input, HIMS density calculation and VITO sensors
Max. instruments per module	5 (digital) or 1 (analog)
Communications	HART® (revision 4)
Cable characteristics	2 wires, shielded, twisted pair, Cmax = 1 µF, Lmax = 9 mH, Rmax = 25 Ω / line
Other Options	
Flange or adapter plates	Adapter plates or flanges for different antennas are available

Notes:

^{*16} Depending upon the other options used and availability of slots for additional module, a twin safety function is possible offering independent relay contacts for prevention of overfill and dry run (contact Honeywell representative.).

^{*17} Under reference conditions.

^{*18} With VITO temperature probe or Spot (Pt100)

^{*19} Various generally available types of elements (RTD, MRT) can be selected.

Identification Code

Pos 1 Device Selection ^{*4}		i.s. term. ²	non i.s. term. ³	slots ⁴
R	SmartRadar FlexLine	-	-	1
S	SmartRadar FlexLine - Special (limited options, consult factory)	-	-	1
M	SmartRadar FlexLine - Migration	-	-	1
Pos 2 Type of Gauge		i.s. term. ²	non i.s. term. ³	slots ⁴
X	Xtreme Performance, W&M type approved with OIML R85 report and sealing facilities ^{*6}	-	-	-
Y	Xtreme Performance, W&M type approved	-	-	-
I	High Performance, for custody transfer acc. to OIML R85, API 3.1B and ISO 4266 with OIML R85 report	-	-	-
H	High Performance, for custody transfer acc. to OIML R85, API 3.1B and ISO 4266	-	-	-
U	Advanced Performance, for inventory control acc. to API 3.1B and ISO 4266 with factory calibration report	-	-	-
A	Advanced Performance, for inventory control acc. to API 3.1B and ISO 4266	-	-	-
Pos 3 Display ^{*1, *2, *4}		i.s. term. ²	non i.s. term. ³	slots ⁴
Z	With Portable Smartview connectivity (only if Pos 4 = B, G, I or W)	-	-	1
I	Integrated SmartView	-	-	1
S	With i.s. terminals for stand-alone SmartView (consult factory)	-	-	1
V	With i.s. terminals for stand-alone SmartView and portable SmartView Connectivity	4	-	1
B	With integrated SmartView and i.s. terminals for stand-alone SmartView	4	-	1
Pos 4 Data Transmission ^{*1, *3, *4}		i.s. term. ²	non i.s. term. ³	slots ⁴
B	Enraf Fieldbus Bi-phase Mark (BPM) GPU protocol	-	2	1
G	RS-232, GPU / Modbus protocol	-	3	1
H	HART or 4-20 mA output	-	2	1
I	OneWireless (ISA100)	-	-	1
W	RS-485, GPU / Modbus protocol	-	3	1
Pos 5 I/O Options ^{*1, *2, *3, *4}		i.s. term. ²	non i.s. term. ³	slots ⁴
-	None	-	-	-
V	VITO temp. and/or water sensor	2	-	1
D	VITO temperature and/or water sensor and 3 HART inputs	2	-	1
E	VITO temperature and/or water sensor and 3 HART inputs and HIMS Density calculations	2	-	1
Q	HART input	2	-	1
R	HART input and HIMS Density calculations	-	4	1
C	Hardware alarms (2x SPDT) 125 V _{ac} , 0.5 A (110 V _{dc} , 0.3 A)	-	4	1
N	Hardware alarms (2x SPDT) 250 V _{ac} , 3 A (40 V _{dc} , 3 A)	-	8	1
O	Hardware alarms (4x SPDT) combined option C and N	3	-	1
S	RTD one spot element 3 wire	4	-	1
T	RTD one spot element 4 wire	6	-	1
U	RTD two spot elements 3 wire	8	-	1
X	RTD two spot elements 4 wire	4	-	1
2	RTD 2 elements MRT / MPT	5	-	1
3	RTD 3 elements MRT / MPT	6	-	1
4	RTD 4 elements MRT / MPT	7	-	1
5	RTD 5 elements MRT / MPT	8	-	1
6	RTD 6 elements MRT / MPT	0	-	1
Z	SIL compliant (1x SPDT) 250 V _{ac} , 3 A (40 V _{dc} , 3 A)	-	2	2
Pos 6, 7, 8 Additional Data Transmission or I/O Options ^{*1, *2, *3, *4, *7}				
-	Select code from Pos 4 or 5 (selection "I" cannot be repeated, if already selected in Pos 4)			
-	Select code from Pos 5			
-	Select code from Pos 5			

continued

Identification Code (continued)

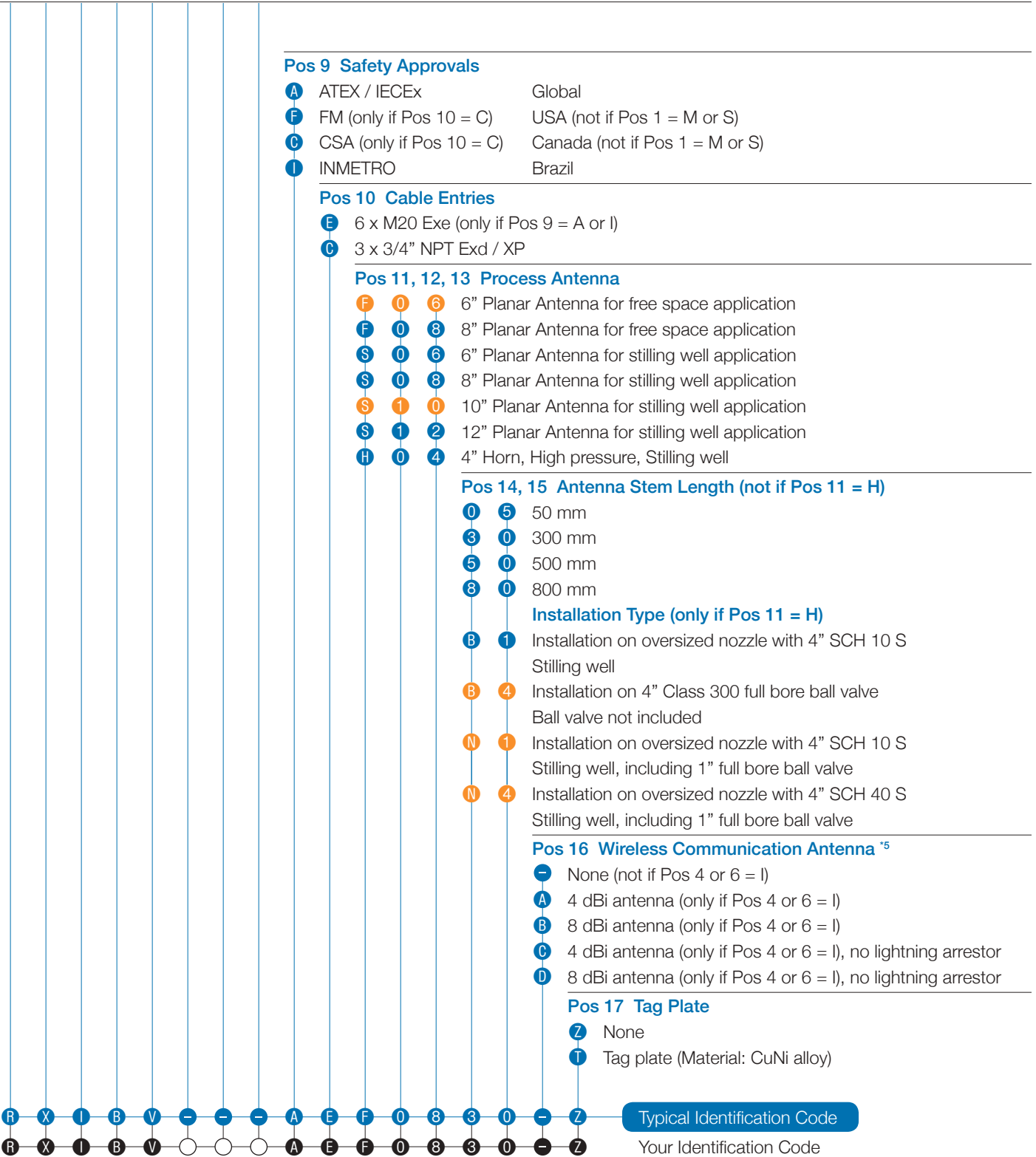

Notes:

Blue positions: Normal delivery

Orange positions: For lead time please consult factory or contact your local sales office

¹ Add terminal count per choice.

² Maximum sum of i.s. terminals = 10

³ Maximum sum of non i.s. terminals = 15

⁴ Maximum sum of slots = 7

⁵ Please make sure the wireless SmartRadar complies to local radio regulations

⁶ For witnessed verification please specify authority.

⁷ If additional data transmission options are needed please consult factory.

⁸ Migration Version is delivered without Antenna and Tank Separator

Dimensional Drawing

Installation Drawings

High pressure horn type H04

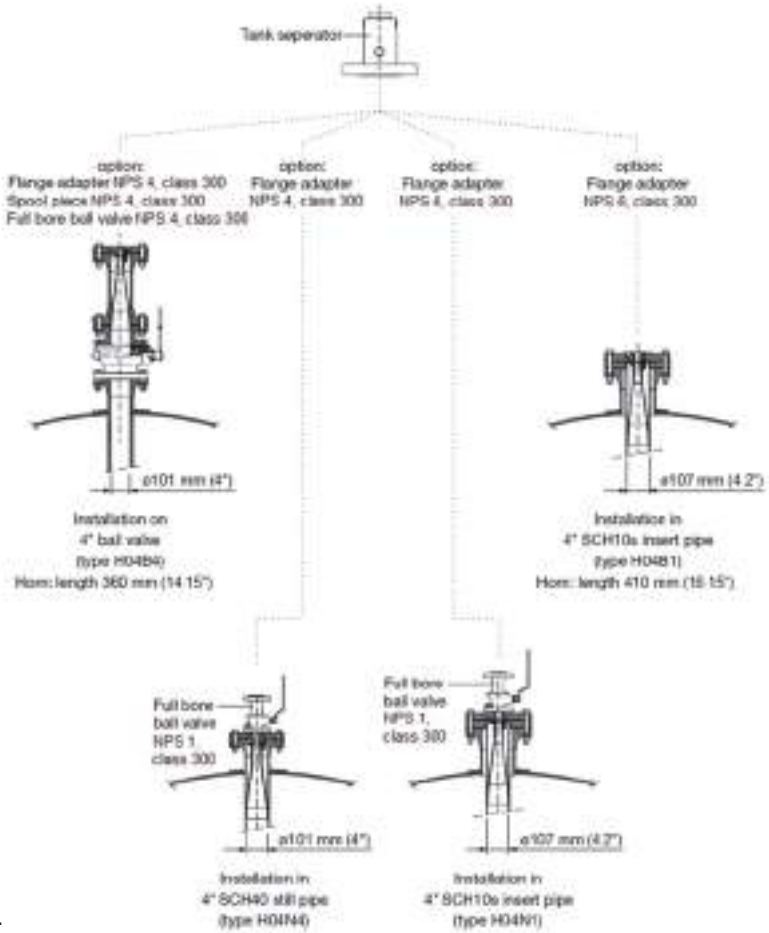

Notes:

- H04 antenna is used for high pressure applications such as LPG and chemical gases.
- Measuring range: up to 75 m (246 ft) (for longer range contact factory).
- Min. process temperature: -200 °C (-328 °F).
- Max. process temperature: +250 °C (+482 °F).
- Max. process pressure: 40 bar / 4 MPa (580 psi).

Antenna Installation Drawings

Free space type F06 and F08

Installation Drawings

Stilling well types S06, S08, S10 and S12

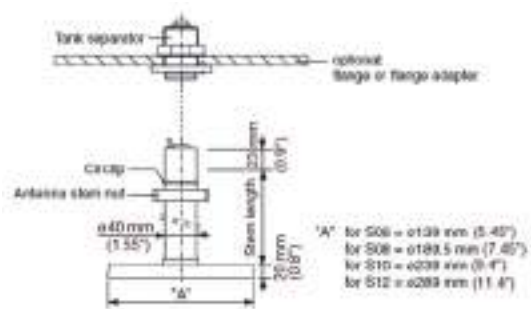
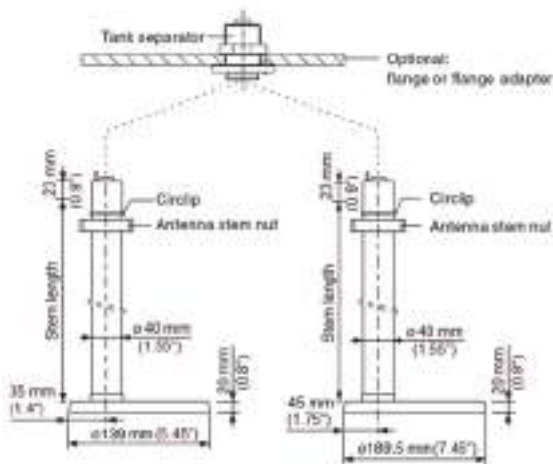

Notes:

- Planar antennas are the best solution for most radar applications.
- Antennas for free space applications are type F06 (for $\geq 6''$ roof nozzle) and type F08 (for $\geq 8''$ roof nozzle).
- Antennas for applications on stilling wells are the types S06, S08, S10 and S12.
- Measuring range: up to 75 m (246 ft) (for longer ranges contact factory).
- Process temperature: -200 °C (-328 °F) to +250 °C (+482 °F). For high temperature and cryogenic applications, easy installation method is described in installation guides. For temperatures above +250 °C (+482 °F), consult your Honeywell representative.
- Max. process pressure: 6 bar / 0.6 MPa (87 psi).
- Stilling well sizes: 6", 8", 10", 12", 14"(S12), 16"(S08), 20"(S10), 24"(S12).
- Stem lengths: 50 mm (1.95"); 300 mm (11.8"); 500 mm (19.7"); 800 mm (31.5").
- For adapter plates or flanges contact your Honeywell representative.

Dimensional Drawing

FlexLine Housing

Dimensions are in mm (in.)

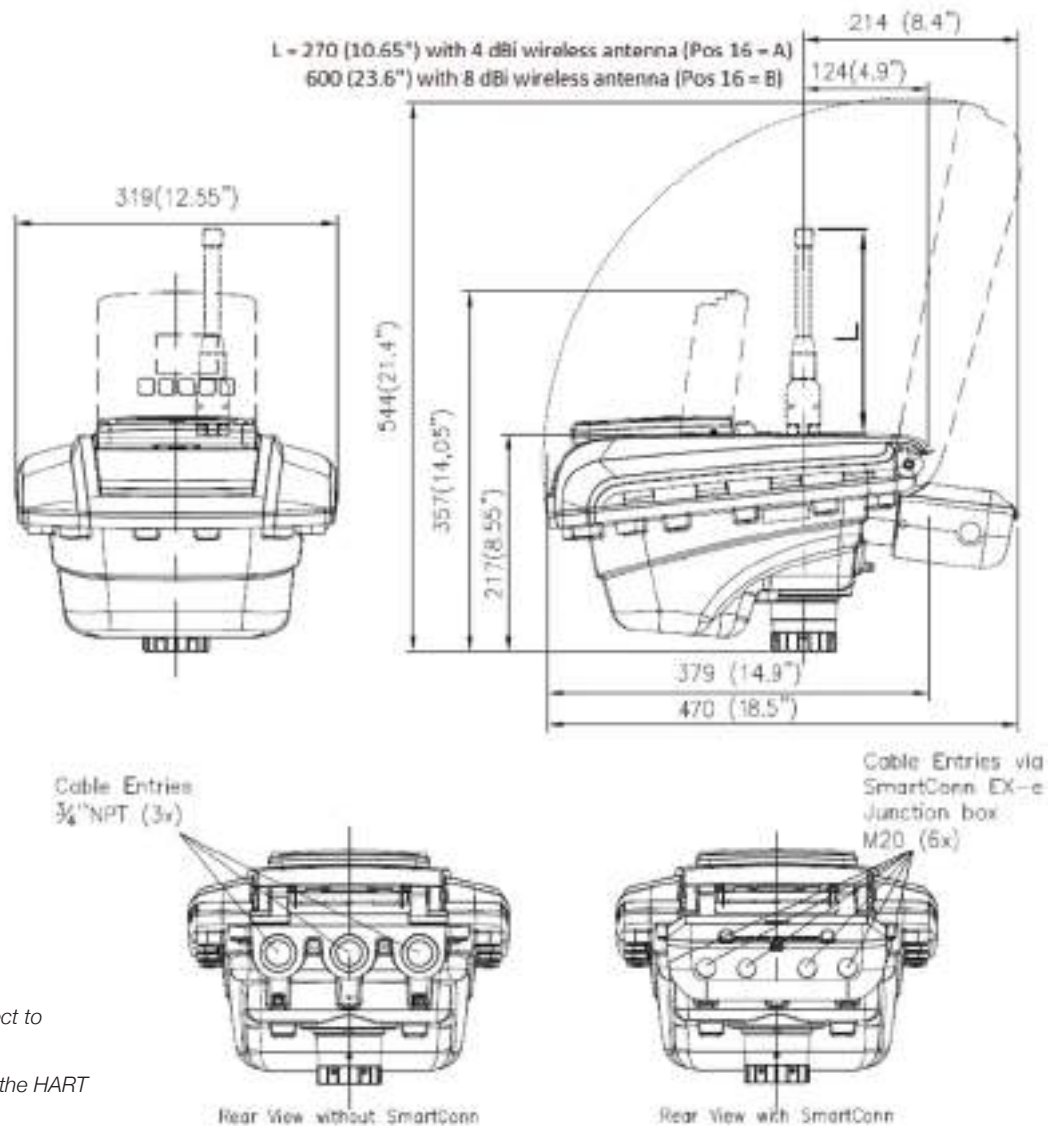

All technical specifications are subject to change without any notice.

HART® is a registered trademark of the HART Communications Foundation.

For More Information

To learn more about Honeywell Enraf's SmartRadar FlexLine, visit www.honeywellenraf.com or contact your Honeywell account manager.

Americas

Honeywell Enraf Americas, Inc.
2000 Northfield Ct.
Roswell, GA 30076
USA
Phone: +1 770 475 1900
Email: enraf-us@honeywell.com

Asia Pacific

Honeywell Pte Ltd.
17 Changi Business Park Central 1
Singapore 486073
Phone: +65 6355 2828
Email: enraf-sg@honeywell.com

Europe, Middle East and Africa

Honeywell Enraf
Delftechpark 39
2628 XJ Delft
The Netherlands
Phone: +31 (0)15 2701 100
Email: enraf-nl@honeywell.com

Honeywell Enraf

Your Terminal Operations Partner