



The intelligent blend controller for all multiple stream blending applications.

As part of the Fusion4 portfolio of loading automation products, the Fusion4 BioBlend delivers a complete solution package for those requiring secure, precision blending capabilities for biofuel and petrochemical products. This compact solution permits the hazardous area control of up to four blend streams simultaneously, to exacting custody transfer accuracy standards. Fusion4 brings advanced features such as rapid start-up and zero downtime firmware upgrades to the BioBlend solution that reduce operational cost.

Overview

Zero in on Accuracy

The Fusion4 BioBlend system is designed to facilitate a precision blending capability for the downstream petroleum and petrochemical refining, storage and distribution sectors. The solution is fully compliant with the EU Measuring Instruments Directive (MID) and features a unique blending algorithm that helps companies achieve the highest blending accuracy to reduce off-spec blends, and the associated costs. This highly configurable Fusion4 solution not only increases accuracy, but is also faster and easier to configure and maintain.

Common applications

- Ethanol
- Bio-Diesel
- Methanol
- Butane
- De-naturants
- Cold flow enhancers
- Markers & Dyes
- Liquid fertilisers

Benefits

Rapid Start-Up

The device can now be configured from new, in less than 45 seconds, utilising the LAD configuration upload facility

Zero Downtime Firmware Upgrades

Firmware updates can be implemented 'live', with the LAD, eradicating the need to power down, open, and exchange EPROM's in the SSC.

Multiple Languages

User selectable for English (US), English (UK), Chinese, Japanese, French, Spanish, Portuguese, Italian, Dutch, German and Polish.

Huge Transaction Archives

The SSC can store 10,000 transaction logs, 128 alarm logs and 100 calibration logs.

Calibration Wizard

Allows the automatic capture of every calibration transaction carried out on the device, including time stamp, calibration volumes, k-factor corrections and even meter serial numbers.

Diagnostics Dashboard

Enables complete device hardware monitoring from a single screen, allowing the immediate analysis of any monitored functions, such as digital and analogue I/O, meter pulsers and RTD's.

Expandable I/O

An additional 'Option' card can be added to the electronics stack to enhance functionality with analogue I/O, RTD, and additional Comm. Port and digital I/O.

The Perfect Blend

The Fusion4 BioBlend system combines the Fusion4 SSC (single stream controller) with application specific, designed blend streams. Each stream provides all of the key elements required to accurately meter and control the blend stream flow, whilst the SSC implements precision control of the blend ratios, monitoring alarm parameters and reconciling totals.

Also available to accompany the Fusion4 MiniPak is the new Fusion4 LAD (Local Access Device). The device is a handheld controller used for interfacing with all Fusion4 products, and enhances the functionality available from the standard IR controller. The LAD facilitates two way data communications between the Fusion4 SSC and the LAD, allowing the rapid, secure transfer of transaction data, configuration files and calibration records and even the 'live' upgrading of firmware while in the field.

Advanced Alarm Handling

Monitoring nearly twice as many injection control parameters than any other device, the SSC utilizes the enhanced graphics capability of the 3.5" QVGA full colour screen to clearly announce and differentiate all alarm conditions.

Flexible Interfacing

Interfacing can now be carried out via the Fusion4 IR Controller, the Fusion4 LAD (local access device), and the Fusion4 Portal software package, in addition to the standard communication protocols such as modbus.

Configurable I/O

Flexible configuration can be achieved through the 'Binding' menu, which allows the assignment of functions to any input or output.



Features

Arrangements

The Fusion4 BioBlend system is offered with optional frame arrangements to support a user definable number of blend streams. The dual frame can be equipped with up to two streams. The quad frame may be equipped with up to four streams. Customer specified arrangements not covered by the modeling code, e.g. larger size blend streams, please contact your local sales office.

Blend Product Supply

The Fusion4 BioBlend requires a pressurised product supply. Typical blend product supply pressure 10 bar / 150 psi. Maximum supply pressure 15 bar / 225 psi. Typically 2 bar / 30 psi differential pressure is required across blend product supply & main product flow.

Filtration

The Fusion4 BioBlend is available with optional filter/strainer, supplied loose, for client field pipe-work installation.

Valve Control – Self Actuated (ATEX ONLY)

The Fusion4 BioBlend is available with 'self actuated' valve control, as standard. The pressure drop across a self actuated blender is up to 3.5 bar.

Valve Control – Hydraulic Power-Pak

The Fusion4 BioBlend is available with a hydraulic power-pak for valve control. The HPP stabilizes valve control pressure, eradicating issues such as higher viscosity products (over 50 cst) and reducing the pressure differential required across the blender (1 bar / 15 psi). The unit is also available with an optional hygroscopic breather to prevent water ingress.

Volume Correction

Temperature compensation option is available with various combinations of pre-installed temperature transmitters or RTD's. Compensation is available for commodity groups A, B, C, D, E and Fame, utilising standards ASTM D 1250-04, ASTM GPA TP-27 (2007) and EN 14214 (2008).

Pressure Monitoring

Optional pressure transmitters are available to facilitate high and low pressure monitoring of each blend stream.

Proving Connections

To aid calibration of the Fusion4 BioBlend, optional proving connections are available pre-installed downstream of the blend unit. A single connection for 'volumetric' proving or dual connections for 'master meter' proving.



Fusion4 LAD (local access device)

The handheld LAD is used to interface with the Fusion4 SSC, allowing tasks such as the adjustment of parameters, resetting of alarms and calibration of the blender. The device facilitates two way data communications between the SSC and the LAD, allowing the rapid transfer of transaction data, configuration files and calibration records and even the upgrading of firmware while in the field. The LAD contains a removable SD card to allow safe area transfer of data.

Fusion4 IR Controller

The hand-held Infra-red remote controller is used to interface with the Fusion4 MiniPak, allowing tasks such as the adjustment of parameters, resetting of alarms and calibration of the injector.

MID Compliance (ATEX ONLY)

The Fusion4 BioBlend is available with optional EU Measuring Instrument Directive (2004/22/EC) compliance. This enables the system to be used for all EU weights and measures approved, custody transfer applications.

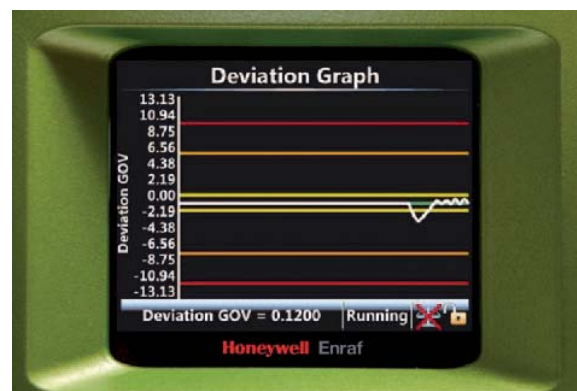

Technical specification

Approvals	SSC	Meter Sensor	Solenoids
ATEX	: II 2 G Ex d [ia] IIB T6 Gb	II 2 G Ex d IIB T6 Gb	II 2 G Ex m II T3/T5 Gb
IECEX	: Ex d [ia] IIB T6	Ex d IIB T6 Gb	Ex m IIC T3/T5 Gb
FM/UL	: FM Class1 Div1 Group C&D T6	Class1 Div1 Group D T4	Class1 Div1 Group ABCD T3A
CSA/CUL	: Class1 Div1 Group C&D T6 Zone 1 Ex d [ia] IIB T6	Class1 Div1 Group C&D	Class1 Div1 Group ABCD T3A
MID Compliance	: WELMEC 7.2, 8.8 : OIML R117-1	WELMEC 8.8 OIML R117-1	
Evaluation Certificate	: TC7852	TC7295	
Flow			
Flow Range	: 20 -268 LPM @ 0.8 - 2 cSt (ethanol) 30 -268 LPM @ 0.4 - 0.8 cSt 50 -268 LPM @ 2 - 5 cSt		
Nominal K-Factor	: 252 Pulses / Litre - Dual Pulse, 90° phase shifted		
Meter Accuracy	: ± 0.30%		
Meter Repeatability	: ± 0.02%		
Pressure Drop	: 1 - 3 bar Self Actuated. ≤1 bar with hydraulic power pack		
Max Pressure	: 16 bar		
Viscosity Range	: 0.4 - 5 cSt		
Environmental			
Operating Temperature	: -20 °C to +65 °C (SSC -40 °C to +65 °C)		
Storage Temperature	: -40 °C to +85 °C		
Protection Class	: IP66		
Humidity	: 5% - 95% Non-Condensing		
Materials			
SSC Enclosure	: Aluminium, Chromitized (class 3)		
Meter	: Casing - 316 SS, Rotor - Anodized Aluminium		
Meter Components	: Bearings - Ceramic, Seals - Fluoro Silicon		
Control Valve	: Casing - 316 SS, Ball Vv - 316 SS, Seals - PTFE		
Actuator (Self Actuated)	: Body - 316 SS, Piston - SS, Gear - SS, Seals - PTFE		
Actuator (Hydr Power Pak)	: Body - Aluminium, Piston - SS, Gear - SS, Seals - PTFE		
Control Manifold	: Body - 316 SS, Seats - SS		
Manifold	: 303 Stainless Steel		
Manifold Connections	: 3/8" NPT		
Solenoid Seals	: PTFE		
Electrical			
Cable Entries (vacant)	: 4 x M20 & 4 x M25		
Voltage	: 88 to 264 VAC		
Flowmeter inputs:	: 1x 5 kHz Dual input, 1 x 5 kHz Single input		
DC Inputs	: 2 x configurable		
AC Inputs	: 2 x configurable		
DC Outputs	: 2 x configurable		
AC outputs	: 3 x configurable		
Communications	: 1 x 2 wire or 4 wire RS485		
Option Card			
RTD Input	: 1x PT100 type, 3 or 4 Wire		
DC Inputs	: 2 x configurable		
AC Inputs	: 4 x configurable		
Analogue Input	: 1x 4-20 mA configurable passive or active		
Analogue Output	: 1x 4-20 mA configurable passive or active		
AC outputs	: 2 x configurable		
Communications	: 1 x 2 wire RS485,		
Interfaces			
Protocols	: Modbus RTU, FlexConn, FMC Smith, Brooks Petrocount		
Display	: 3.5" QVGA colour TFT LCD screen		
Languages	: English (US), English (UK), French, German, Spanish, Dutch, Chinese, Japanese, Polish, Italian, Portugese.		
Handheld Devices	: Fusion4 LAD (local access device), Fusion4 IR Controller (Infra Red)		
Mechanical			
Connections	: ANSI class 150 RF Flanged		
Filtration	: Optional 80 mesh Basket Strainer		

General Arrangement

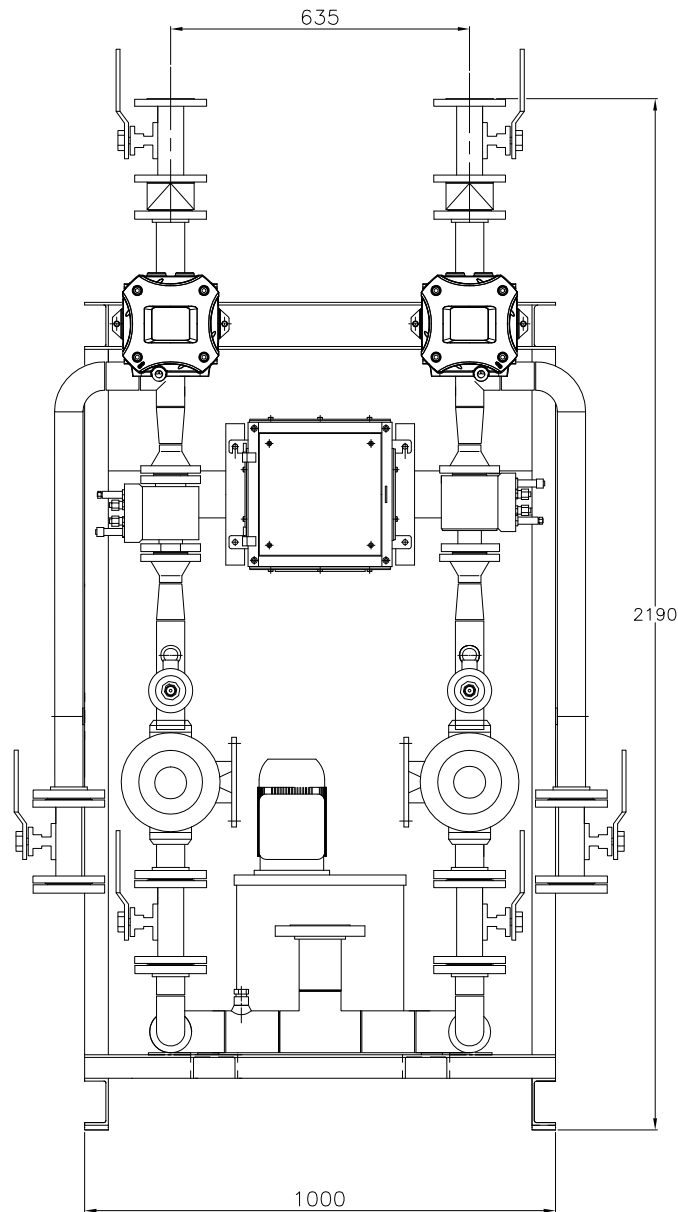

For More Information

To learn more about Honeywell Enraf's solutions, contact your Honeywell Enraf account manager or visit www.honeywellenraf.com.

Americas

Honeywell Enraf Americas, Inc.
2000 Northfield Ct.
Roswell, GA 30076
USA
Phone: +1 770 475 1900
Email: enraf-us@honeywell.com

Asia Pacific

Honeywell Pte Ltd.
17 Changi Business Park Central 1
Singapore 486073
Phone: +65 6355 2828
Email: enraf-sg@honeywell.com

Europe, Middle East and Africa

Honeywell Enraf
Delftechpark 39
2628XJ Delft
The Netherlands
Phone: +31 (0)15 2701 100
Email: enraf-nl@honeywell.com

EN-11-12-ENG
August 2011
© 2011 Honeywell International Inc.

Honeywell Enraf